



Manufacturer will, at its option, replace or repair without charge to the original purchases, any part or parts manufactured by it and found, upon examination, to be DEFECTIVE IN MATERIAL AND/OR WORKMANSHIP if received for such examination within the stated warranty period (1 YEAR), which begins on the date of original purchase.

Damage resulting from accident, abuse, or neglect are conditions under which warranty cannot be claimed. Nor will warranty apply to damage resulting neither from failure to follow the manufacturer's instruction for operation and maintenance nor from the improper selection of a particular application.

All transportation charges on, and damage and loss incurred in connection with the transportation of parts submitted for replacement or repair under this WARRANTY shall be borne by the purchaser.

No other warranties, guarantees, or liabilities, either implied or expressed, will be the responsibility of Amazing Machinery.

For warranty or service work please contact Amazing Machinery.

Read the following information for contact details.

Amazing Machinery, Inc.
3807 Old Tasso Rd. NE
Cleveland, TN 37312-5732
1 (800) 504-7435

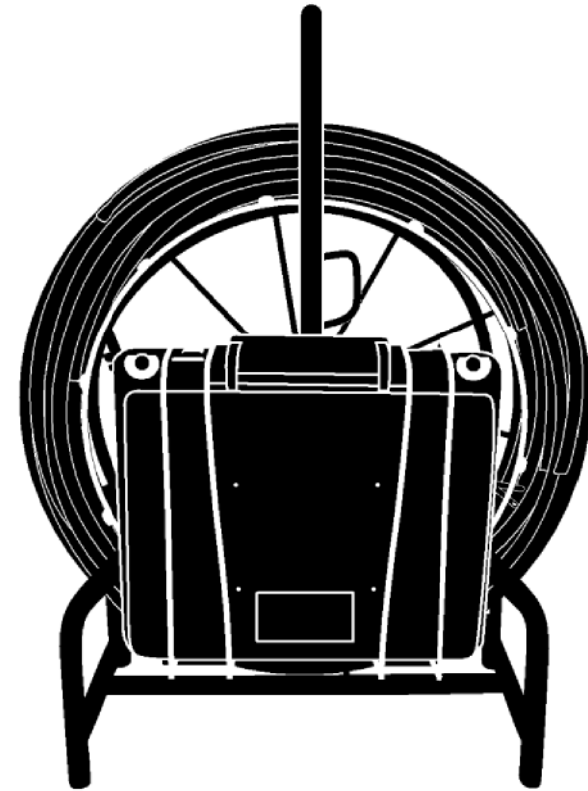

VIZTRAC User's Guide

- | | | | |
|--|----------------------------------|----------------------------------|---|
| <input type="checkbox"/> STANDARD FIXED HEAD | <input type="checkbox"/> 100' | <input type="checkbox"/> 130' | <input type="checkbox"/> 150' |
| | <input type="checkbox"/> 200' | <input type="checkbox"/> 225' | |
| <input type="checkbox"/> AM 100 | <input type="checkbox"/> AM 200 | <input type="checkbox"/> AM 240 | <input type="checkbox"/> 512hz Built-In Sonde |
| <input type="checkbox"/> AM 140 | <input type="checkbox"/> AM 200B | <input type="checkbox"/> AM 240B | |

DVR Quick Start Instructions

- After turning system **power ON**, ensure monitor is on the **correct Input**:
 - Video should show **“Insert SD Card”** if none present, or an **SD Card Icon** in the **Lower Right** and a **Camera Icon** in the **Upper Right** if already loaded.
 - If neither **“Insert SD Card”** nor icons are present, change **Video Input to V1** with **Monitor’s Remote** and check the **Power LED on the DVR**.
 - Leds from Left-to-Right: Menu (Green), Preview (Green), Record (Green), Power (Red)
 - If **no lights** are on, check **connectors at the back of the DVR**.

Main Camera Modes:

- **Standby Mode:** Indicated by a “Camera Icon” in the Upper Right and an SD Card Icon in the Lower Right. In this mode, the monitor shows what the Camera sees in real-time.
 - Press **“OK”** in this mode to **Start “Recording Mode”**.
 - This should be the default mode after startup. If not, consult the User Manual.pdf in the included CD to adjust DVR settings.
- **Recording Mode:** Indicated by a flashing “Red Circle” Icon in the Lower Left, and an increasing Recording Time count in the Upper Right. The DVR is actively recording what you see on the monitor.
 - Press **“Stop”** in this mode to **Stop Recording**.
 - After stopping a recording, the DVR defaults to “Playback Mode” with the newly made file ready to play.
- **Playback Mode:** Indicated by an “Arrow” Icon in the Upper Right, Video Length Current/Total in the Top Center, and Video Status Icons (Play, Pause) in the Lower Left. In this mode the DVR is playing/waiting to play a saved video.
 - Press **“ESC”** from here to go to **“File List Mode”**.
 - To return to Standby Mode from Playback Mode: Press **“ESC”**-> File List Mode, **“ESC”** -> Main Menu, Select **“EXIT”**.

How to work basic functions with your DVR

TO SET UP HOW YOU WANT TO RECORD- example manually by remote, motion detection etc.

- Remove SD card
- Press MENU on remote
- Scroll down to REC MODE and press OK

DROP DOWN BOX APPEARS WITH FOLLOWING OPTIONS

Manual - by remote

Motion detection - starts recording when there is motion

Power up rec - starts recording as soon as camera is turned on (**MUST HAVE MEMORY CARD INSERTED BEFORE TURNING ON CAMERA**)

Scheduled - weekly or once (you pick the days, date, and time) **Scheduled instructions below these

- Scroll up or down to option you want and push OK on your remote
- Scroll down to EXIT and hit OK. Now it’s ready for whichever you chose (except scheduled)

***FOR SCHEDULED RECORDING

- Press Menu on your remote
- Scroll down to REC SETTING and press OK
- Choose SCHEDULED TIME and press OK
- Pick a GROUP - 1,2,3 or 4 and press OK
- Scroll over to choose your settings and use arrows to move around screen
- Press OK when you choose your days, dates, times
- Press ESC on Remote to get to main menu
- Scroll down to EXIT and press OK

TIPS ON RECORDING/HOW TO MANUALLY RECORD (if that’s how it’s set up) WITH YOUR REMOTE

On some of the cameras, the DVR remote sometimes has interference with the monitor and turns the monitor off whenever you press STOP on your DVR remote. Instead of pressing STOP, press ESC and this should stop your monitor from turning off.

- Insert your SD card
- Press OK to start recording
- Press ESC (NOT STOP) to stop recording

TO PLAY A VIDEO

- Press Menu
- Scroll down to PLAYBACK and press OK
- Scroll down to the file you want to view and press OK
- Press PLAY to start the video
- Press ESC to exit file
- Press ESC to get to main menu and scroll down to EXIT and press OK

TO DELETE A VIDEO

- Press MENU and scroll down to PLAYBACK and press OK
- Scroll to file you want to delete and press DEL
- At pop up screen scroll to YES OR NO TO DELETE and press OK
- Press ESC to get to main menu
- Scroll down to EXIT and press OK

TABLE OF CONTENTS

Diagram & Equipment Specifications	4
Equipment Specification & Safety Instructions	5
AM 100/140 Operation	6
AM 200/240 Operation	7
Control Panel for AM 200/240.	8
AM 200/240 Sonde/DVR Operation	9
AM 200B/240B Operation	10-11
Control Panel for AM 200B/240B	12
Trouble Shooting	13-16
Warranty Information	17
How to work basic functions with your DVR	
.	Inside back cover

DIAGRAM & SPECIFICATIONS

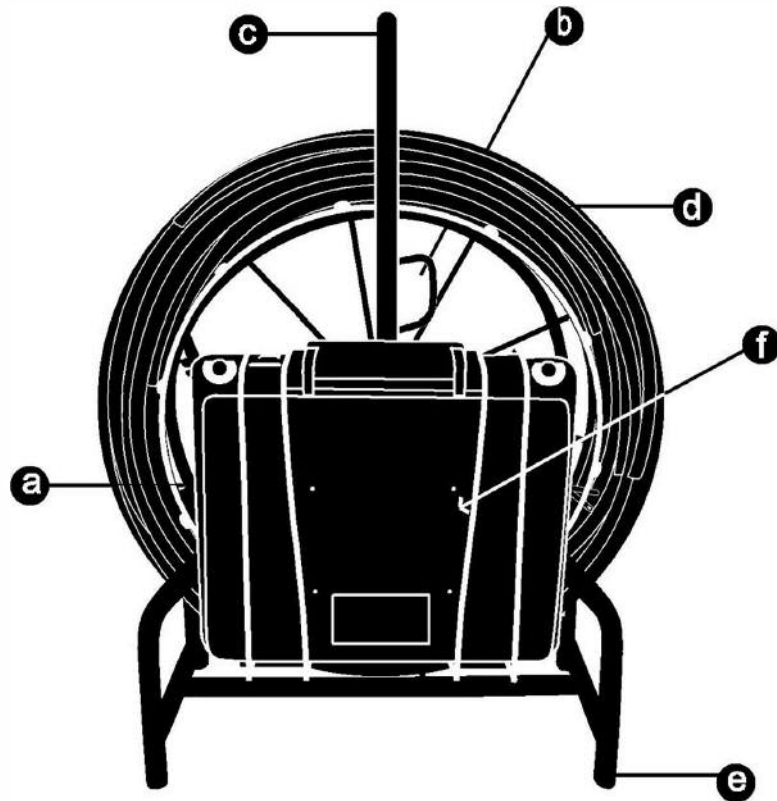

- A. Camera Head
- B. Cable Guide
- C. Powder Coated Frame
- D. Heat Treated Epoxy Sealed SV Cable
- E. Rubber Feet
- F. Control Box

Included Not Pictured
- 7" LCD Color Monitor
- 512 hz Built in Sonde
(Not on the AM100/140)
- DVR (Not on the AM100/140)

WARRANTY INFORMATION

LIMITATION OF LIABILITY

NOTE - All Warranties offered by or passed through Amazing Machinery to you the customer include parts and labor.

Freight charges will NOT be accepted under warranty claims.

NOTE -All Amazing Machinery and Factory Warranties are not transferable.

NOTE -The warranty contained herein is in lieu of all other warranties express or implied, including any implied warranty of fitness for particular purpose.

NOTE - It is understood that a manufacturers limited warranty pertains to equipment used in it's prescribed manner, without abuse, and does not include wear and tear.

NOTE - All freight charges incurred on warranty situations are the responsibility of the customer.

NOTE - Amazing Machinery and Equipment Manufacturer liability for special, incidental, or consequential damages is expressly disclaimed. In no event shall any liability exceed the purchase price of the product in question.

NOTE - Specifications, Warranties and Pricing are subject to change without notice.

*Refund does not include shipping/handling fees. No refund will be given for installation kits. Customer is responsible for lost or misdirected packages. It is recommended that the customer insure the package for its full retail value. This warranty does not cover or include any damage as a result of acts of God, improper installation, alteration, negligence or abuse.

moisture. If head has been tampered with or abused, a seal may have broken and allowed moisture into the head. This would cause a blurry or scrambled picture. Camera System should then be diagnosed by a repair technician

COLORFUL IMAGES DISTORTED COLORS

Possible Problems:

- Monitor Broken or Damaged
- Seal broken or compromised
- Moisture in head-Camera head Fried
- Faulty Video Cable

TRY THIS

Look at camera head and check for any type of moisture. If head has been tampered with or abused a seal may have broken and allowed moisture into the head. This would cause the camera head to fry and create strange distorted colors to form on the screen. Camera system should then be diagnosed by a repair technician.

EQUIPMENT SPECIFICATIONS

- Wrong setting set on Monitor or Recording Device
- Faulty Video Cable
- Broken or damaged monitor or recording device
- Broken or loose connection in camera head or control box.

Try This:

Press V₁/V₂ button on the monitor

- Read Monitor or Recording Device instructions manual to make sure you are on the proper settings.
- Be sure to check the batteries in all remote controls*

SAFETY INSTRUCTIONS

and none of the solutions above have worked, the equipment will need to be diagnosed by a technician. Please call the repair department.

BLURRY OR SCRAMBLED PICTURE

Possible Problems:

- Monitor Broken or Damaged
- Seal broken or compromised
- Moisture in head
- Camera Head Fried
- Faulty Video Cable

Try This:

AM 100/140 OPERATION

The AM 100/140 camera DOES NOT come with a sonde transmitter for locating or a DVR for recording.

Once you have inspected all components to make sure that they are not damaged or broken, plug the unit into an outlet. Press the power switch and it will turn the power on to the unit. You may need to press the power switch on the monitor if this is the first time the system has been started. You do not need to power the monitor off after use as the main power switch will do this for you.

To rotate the angle on the monitor, press the 2nd button from the left (looks like arrows in a circle) on the monitor to rotate the screen.

If you are having trouble with your unit not functioning properly, please see the trouble shooting section or contact one of our technicians.

“NO SIGNAL” FLASHING ON MONITOR

Possible Problems:

- Wrong setting set on Monitor or Recording Device
- Faulty Video Cable
- Broken or damaged monitor or recording device
- Broken or loose connection in camera head or control box.

Try This:

Press V₁/V₂ button on the monitor

- Read Monitor or Recording Device instructions manual to make sure you are on the proper settings. Be sure to check the batteries in all remote controls.

If you can play back on the Monitor or Recording Device and none of the solutions above have worked, the equipment will need to be diagnosed by a technician. Please call the repair department.

BLURRY OR SCRAMBLED PICTURE

Possible Problems:

- Monitor Broken or Damaged
- Seal broken or compromised
- Moisture in head
- Camera Head Fried
- Faulty Video Cable

Try This:

Look at camera head and check for any type of

the repair department to have unit diagnosed.

NO LIGHTS - NO VIDEO

Possible Problems:

- Broken or damaged control box
- Damaged or faulty connection within camera head

Please call the repair department for instructions on how to have the equipment diagnosed.

HORIZONTAL WAVY LINES ACROSS SCREEN

Possible Problems:

- 512 Hz Transmitter Built in Head is in the ON position.
- Faulty Video Cable
- Dirty Monitor

Try This:

If the transmitter that is built inside the camera head is in the ON position, the frequency that it puts out interferes with the camera head frequency, and will create wavy lines across your monitor. Inspect your pipe and then locate to avoid picture distortion. If the suggestions above have not eliminated the problem there is a possibility that your Monitor or Recording Device is dirty and needs to be cleaned. See Monitor Instruction Booklet for cleaning instructions. If problem persists, please contact a repair technician at Amazing Machinery.

AM 200/240 OPERATION

AM 200/240 INSPECTION CAMERA

Once you have inspected all components to make sure that they are not damaged or broken, plug the unit into an outlet. Press the power switch and it will turn the power on to the unit. You may need to press the power switch on the monitor if this is the first time the system has been started. You do not need to power the monitor off after use as the main power switch will do this for you.

Check to see if the lights on your camera head are on. If they are, proceed to the next step. If they are not, check your power receptacle and refer to the trouble shooting section of your manual.

AM 200/240 CONTROL PANEL

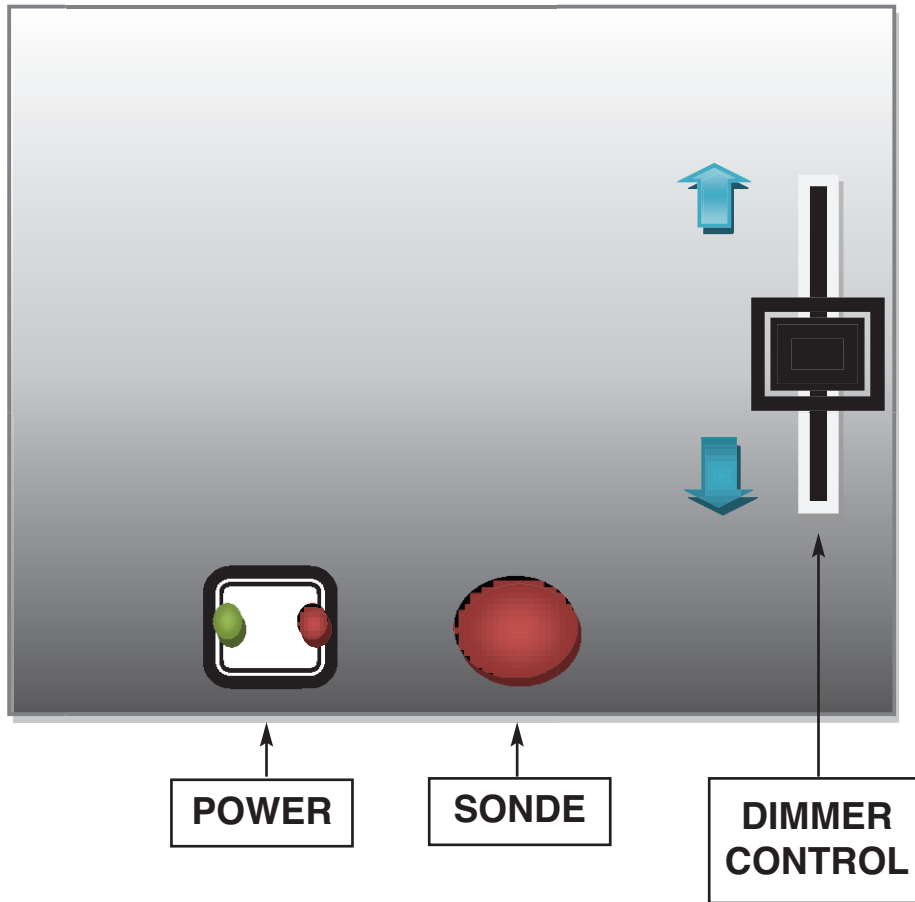

TROUBLE SHOOTING

The trouble shooting guidelines below are designed to help you out in the field. If you cannot figure out the problem or fix it without voiding your warranty, please call the number listed in the back of your manual to speak with a repair technician.

LIGHTS TURN ON - NO VIDEO

Possible Problems:

- Check DVR and make sure all cords are plugged into back securely
- Faulty Video Cable
- Broken or loose connection in Camera Head

Call the repair department to get the proper instructions on how to have the equipment diagnosed.

VIDEO WORKS - LIGHTS DON'T TURN ON

Possible Problems:

- Lights Burnt out
- Dimmer Control Switch Turned Down
- Dimmer Control Switch Broken
- Broken or loose connection in Camera Head

Try This:

Turn dimmer control all the way down and then all the way back up. check to see if GFCI is working properly with the camera system. If problem still persists, please contact

AM 200B/240B CONTROL PANEL

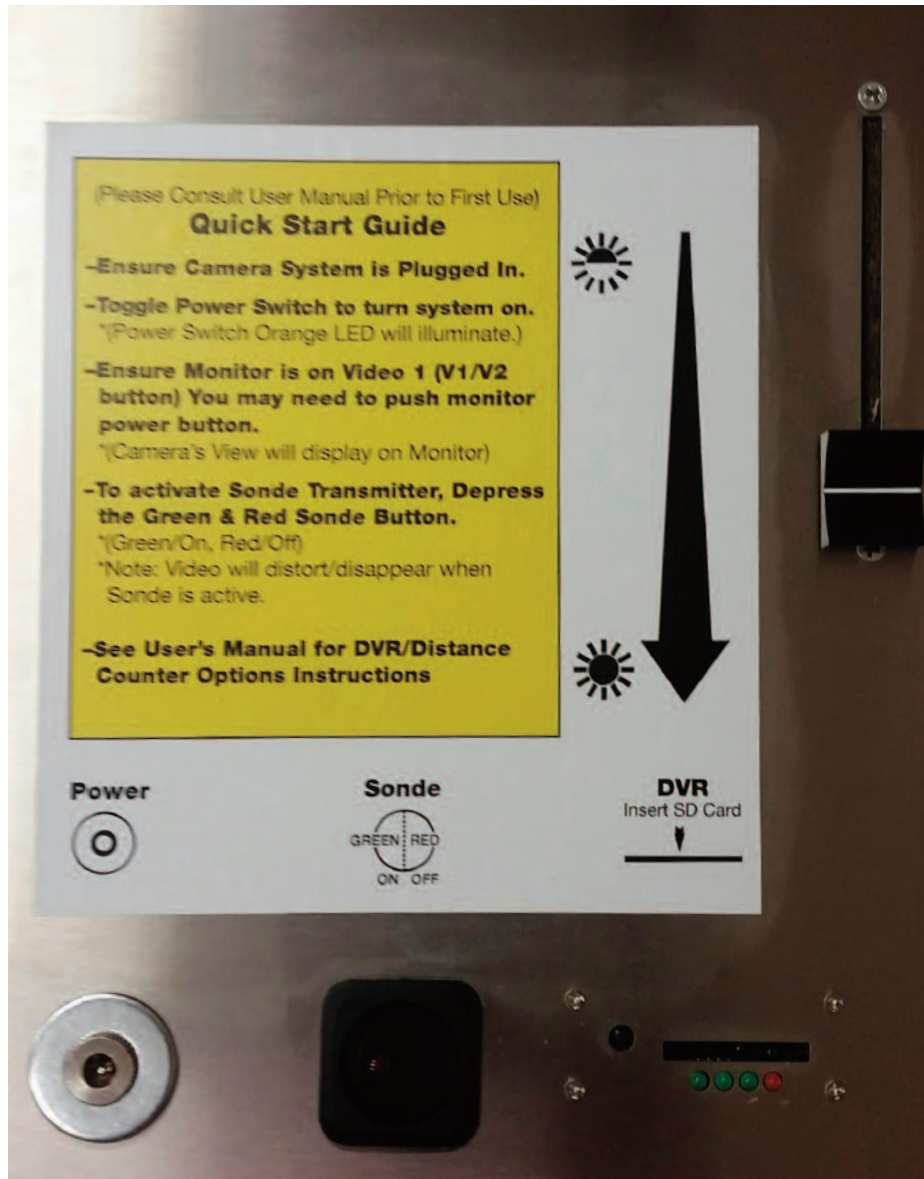

AM 200/240 OPERATION

SONDE OPTION:

Your camera came equipped with a 512 Hz transmitter, built inside the camera head. Please refer to the previous diagram 1.A to activate the built in transmitter. Simply press the sonde switch located on the main control panel. The switch will light up. You will need to be sure to have your locator set to 512 Hz or you will not be able to locate the transmitter.

•NOTE - when sonde is activated you have a scrambled video signal or no signal at all.

DVR OPTION:

Your camera also came with a DVR. This will allow you to record the image that you see. You will need a 2-32 GC SD card to capture the video. Insert the SD card. Please see **How to work basic functions with your DVR** (on inside back cover) section in order to set your camera up to record.

AM 200B/240B OPERATION

When you receive the camera, plug the battery up with the enclosed power adapter into the input port to get a full charge. It usually takes between 7-8 hours to charge when it's at 0%. **ALWAYS MAKE SURE THE VOLTAGE ON THE BATTERY IS SET AT 20 VOLTS, A LOWER SETTING CAN AFFECT SOME FEATURES ON THE CAMERA (IF YOU NEED TO RESET—HOLD THE POWER BUTTON DOWN ON THE BATTERY UNTIL THE VOLTAGE FLASHES, THEN KEEP PRESSING THE POWER BUTTON UNTIL IT GETS 20V AND RELEASE THE BUTTON).**

To power up the camera with the battery, simply plug one end of the enclosed cord in to the DC output port on the battery pack and the other end into the jack on the control panel. Adjust your lights with the black slide knob on the control panel. Press the sonde button to activate the sonde (screen will become distorted). Insert the memory card into the slot located on the panel where DVR is. **(RECORDING SETTING INSTRUCTIONS FOR DVR ARE ON LAST PAGE OF THIS USER GUIDE)**

IF YOUR BATTERY DIES WHILE YOU'RE ON THE JOB, YOU CAN USE THE POWER ADAPTER THAT CHARGES THE BATTERY TO POWER UP YOUR CAMERA.

AM 200B/240B OPERATION (CONT.)

9" MONITOR ROTATION FEATURE

To rotate the angle on the monitor, first determine if you have the push button monitor or the touch button monitor.

PUSH BUTTON MONITOR

Push M button on monitor until rotate option is on the screen. Then press + or – to view in different angles. By remote - press menu until rotate shows, then press ←or→ to view different angles.

TOUCH BUTTON MONITOR

Press 2nd button from left on monitor (looks like a book) 6 times until you see down, then press + or – to view different angles. By remote, press menu 6 times until you see down, then press ←or→ to view different angles.

****IF YOU ARE USING YOUR BATTERY TO OPERATE THE SYSTEM AND NOTHING IS WORKING, MAKE SURE YOUR VOLTAGE IS SET AT 20 VOLTS ON THE BATTERY.**